

A Complete Range of Motion Products

for Efficient Machine Control

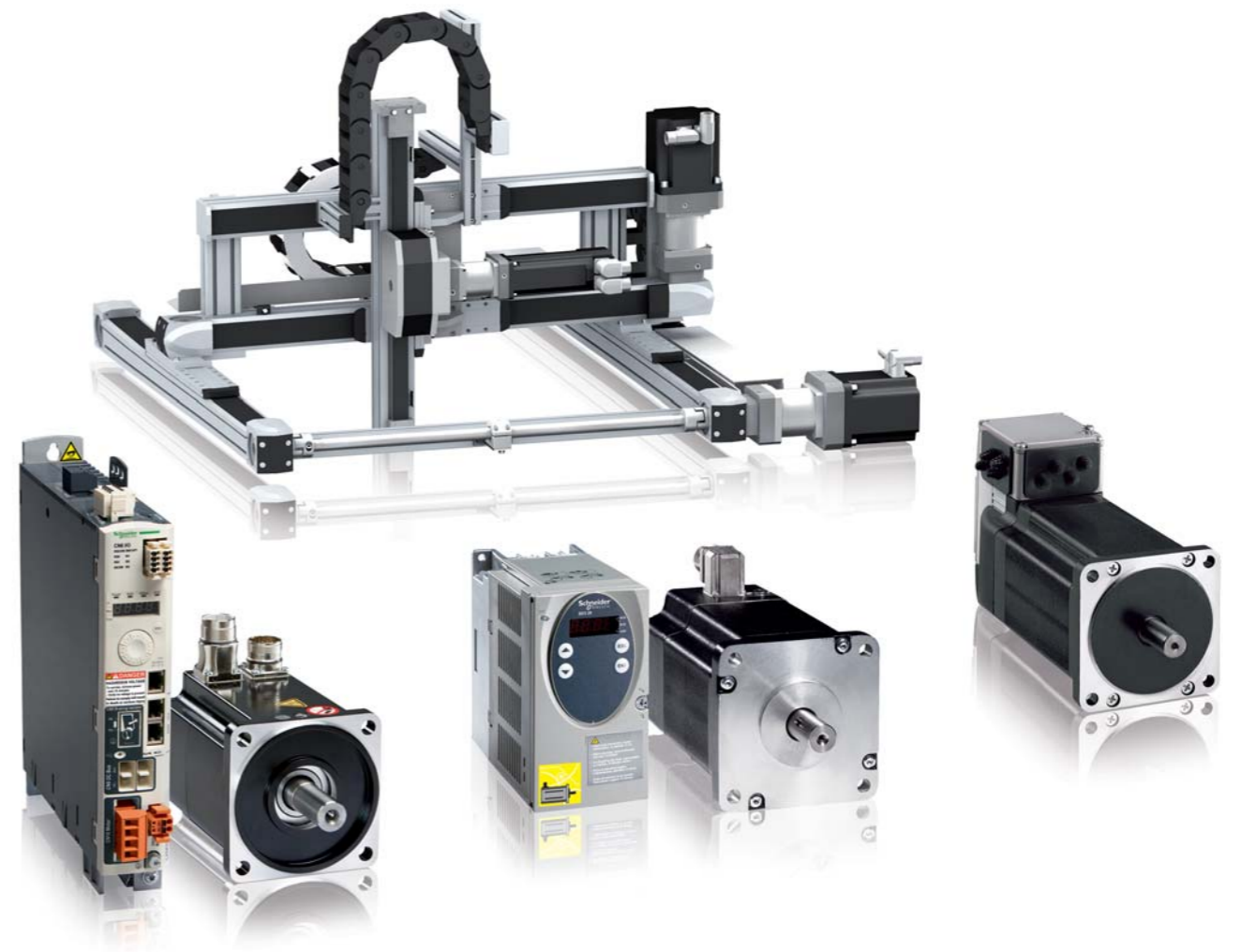

Schneider Electric Industries SAS

Head Office
35, rue Joseph Monier
CS 30323
92506 Rueil-Malmaison Cedex
France

www.schneider-electric.com

ART. 837678

Due to evolution of standards and equipment, characteristics indicated in texts and images in this document are binding only after confirmation by our departments.

Concept, text: Dr. Jan Vester
Design: BrainFactory
Photos: Schneider Electric
Printing:

DIA7ED1091101EN

Date : 12 / 2009

Schneider
Electric

Your Partner for Motion Control in Machine Automation

Motion controllers, drives, motors and linear motion axes – Schneider Electric offers a complete range of motion products and solutions for your specific applications.



Packaging



Material working



Material handling



Printing

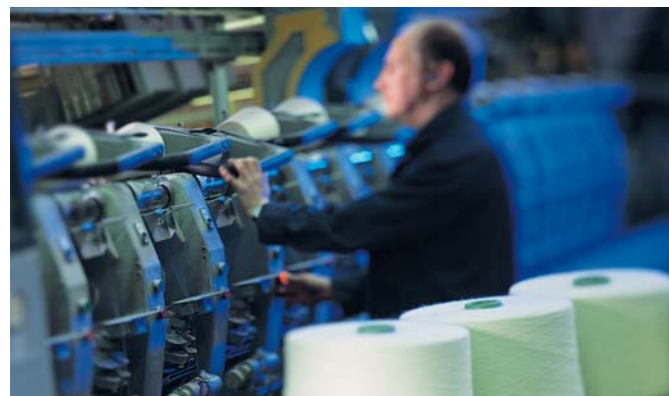

Textile

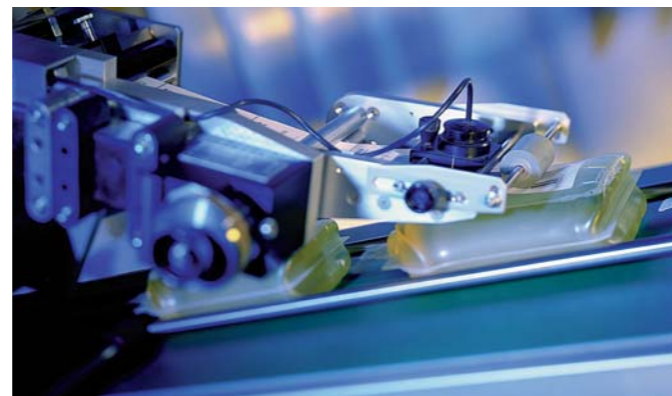

Labelling

Maximum Productivity for Your Machines

Complete Product Range

- The complete range of Schneider Electric motion products is made to highest quality standards
- The products are designed for maximum consistency and interoperability and use a comprehensive platform of common tools and accessories

Solution Expertise

- A global team of experts versed in virtually all industries and applications assist you with their comprehensive solution competency
- Schneider Electric is able to provide you with highly productive machine solutions to take your know-how to the next level

Simplicity

- All our motion products are designed for maximum ease over the entire machine lifecycle to reduce costs and make your machine processes even more productive

Openness

- Our products support practically all standardised motion interfaces – mechanical, software and communication interfaces
- This allows you to efficiently design machines which can easily be integrated into your customers' automation architectures

Innovation and Standardisation

- Schneider Electric has an impeccable reputation as a major innovation driver in the industry
- To make sure new technologies can be efficiently used, we support international standards and actively participate in standardisation initiatives such as CiA (CAN in Automation), ODVA (Open Device-Net Vendor Association), SERCOS III, PLCopen

See how a complete range of products



solution competency



the power of innovation



global availability



energy efficiency specialists

make Schneider Electric your partner of choice for cost-effective and energy-efficient machine automation

Schneider Electric - you can rely on us!

Discover Our Solutions for Your Motion Application

This architecture combines a Modicon LMC058 motion controller, Altivar 32 variable speed drives, TeSys U motor starters, distributed I/Os via CANopen and Lexium 32 servo drives via CANmotion. This implementation brings maximum modularity, flexibility and openness to machines due to CANopen, EtherNet/IP and CANmotion.

Horizontal bagging machines

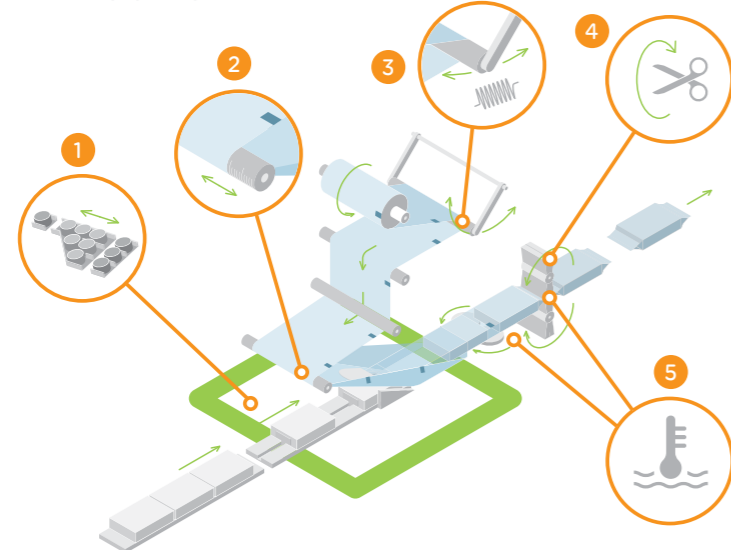

Vertical bagging machines

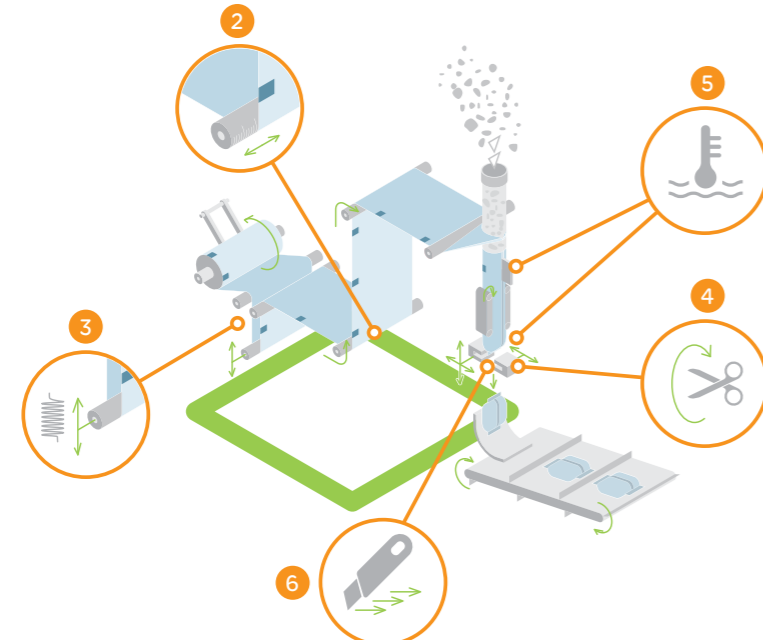

- Application functions**
- 1 Grouping / ungrouping
 - 2 Lateral film position control
 - 3 Digital film tension control
 - Analog film tension control
 - 4 Rotary knives
 - 5 Heating temperature control
 - 6 Flying shear

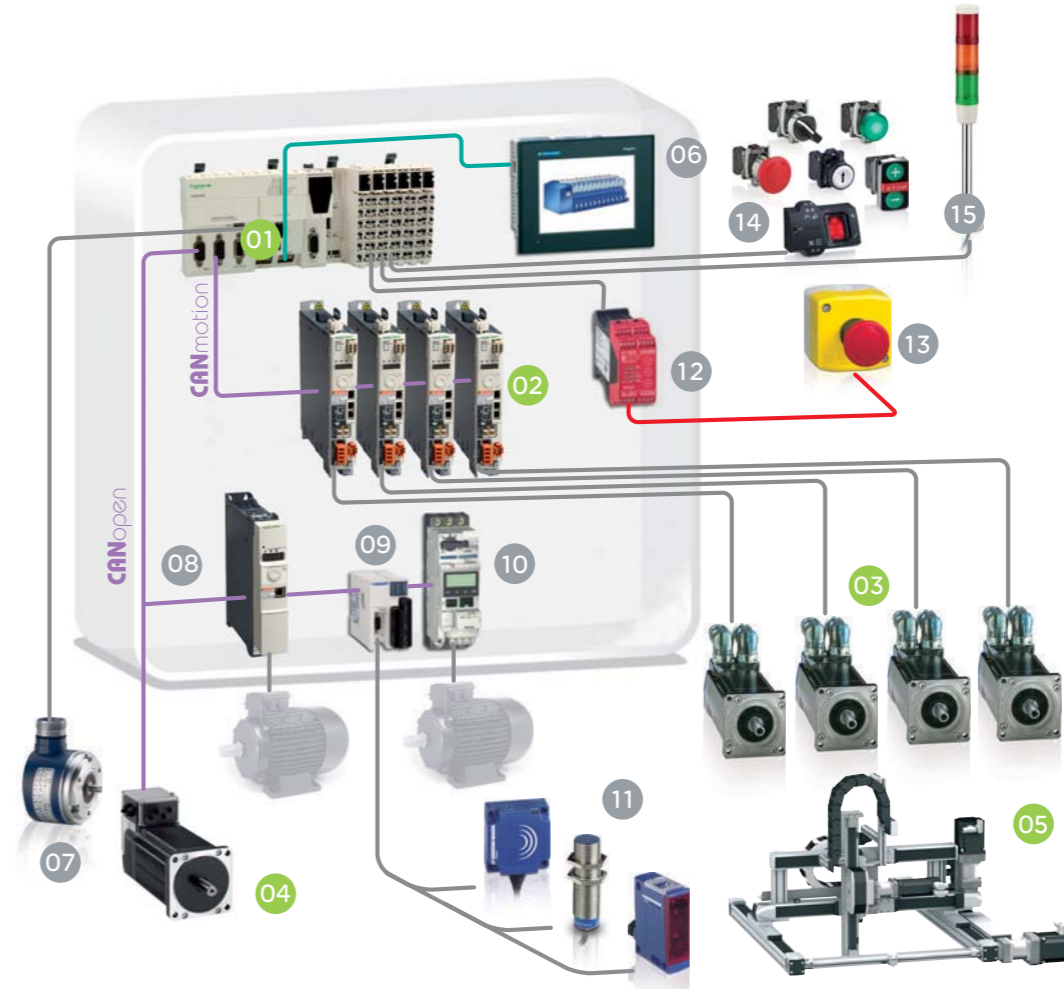

Motion products

- 01 Controller **Modicon LMC058**
- 02 Servo Drive **Lexium 32**
- 03 Servo Motor **Lexium BMH, BSH**
- 04 Integrated Drive **Lexium ILA, ILE, ILS**
- 05 Multi-Axis System **Lexium MAX R3**

Other Schneider Electric products

- 06 Graphic terminal **Magelis XBT GT ...**
- 07 Encoder **OsiSense XCC**
- 08 Variable speed drive **Altivar 32**
- 09 Distributed I/O **Advantys OTB**
- 10 Motor starter **TeSys U**
- 11 Detectors **Osisense XC/XS/XU/XM/XX ...**
- 12 Safety controller **Preventa XPS MC ...**
- 13 Emergency stop **Harmony Xalk ...**
- 14 Pushbuttons & switches **Harmony XB4/5**
- 15 Signaling unit **Harmony XVM**

Machine performance

- Synchronisation of 4 axes in 2 ms or 8 axes in 4 ms with the LMC 058 motion controller
- Maximum machine productivity due to highly dynamic motor control of the Lexium 32 servo drive

Fast machine commissioning

- Easy integration of Lexium Integrated Drives via CANopen interface
- Ready-to-use application function blocks and libraries for easy programming
- Synergetic use of Lexium 32 servo drives and variable Altivar 32 speed drives with common tools, common software and identical mounting and wiring concepts

Discover Our Solutions for Your Motion Application

A CANopen network with Modicon M238 programmable controller, Altivar 312 variable speed drive, Lexium 32 servo drives and Magelis XBT GT display unit brings maximum modularity, flexibility and performance to simple machines.

Boxing machines

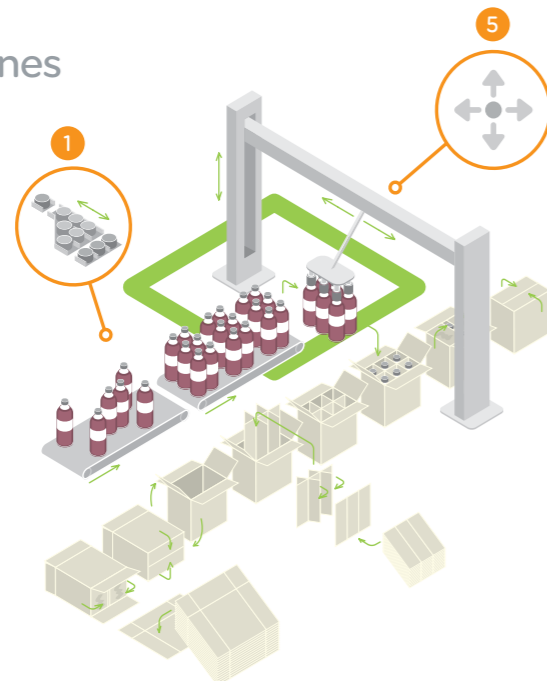

Shrinking machines

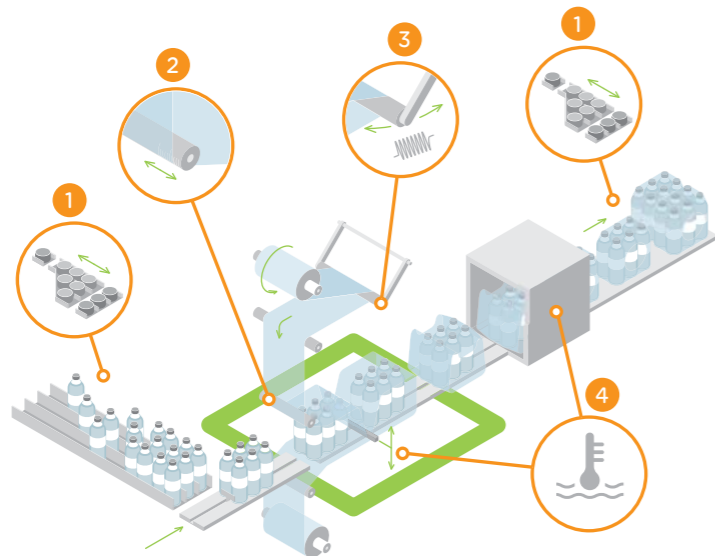

Application functions

- 1 Grouping / ungrouping
- 2 Lateral film position control
- 3 Digital film tension control
- 4 Analog film tension control
- 5 Heating temperature control
- 6 Pick & Place

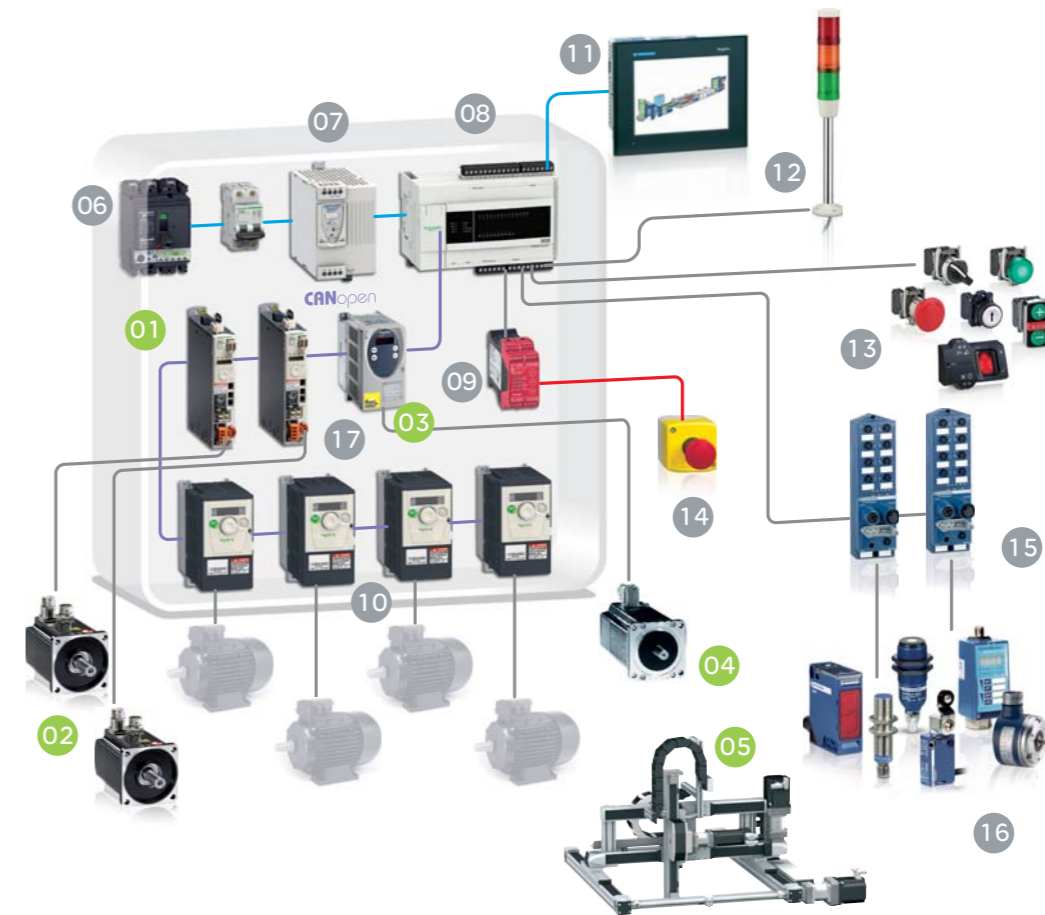

Motion products

- 01 Servo Drive **Lexium 32**
- 02 Servo Motor **Lexium BMH, BSH**
- 03 Stepper Drive **Lexium SD3**
- 04 Stepper Motor **Lexium BRS3**
- 05 Multi-Axis System **Lexium MAXR3**

Other Schneider Electric products

- 06 Circuit breaker **Compact NSX / Multi 9 ...**
- 07 Switch mode Power supply **Phaseo ABL 8 ...**
- 08 Logic Controller **Modicon M238 ...**
- 09 Safety modules **Preventa XPS ...**
- 10 Variable speed drive **Altivar ATV 312 ...**
- 11 Display unit **Magelis XBT GT ...**
- 12 Signaling unit **Harmony XVM ...**
- 13 Pushbuttons & switches **Harmony XB4/5 ...**
- 14 Emergency stop **Harmony XALK ...**
- 15 Distributed I/Os IP20 **Advantys FTB ...**
- 16 Detectors **Osisense XC/XS/XU/XM/XX ...**
- 17 Enclosure **Spacial 3D ACM & ACP**

Machine performance

- Highly dynamic positioning due to the speed bandwidth of 1.6 kHz of the Lexium 32 servo drive
- Positioning speeds of up to 8 m/s with Lexium PAS B portal axes

Flexibility

- Large choice of fieldbus modules for Lexium 32 (EtherNet IP, CANopen, Profibus DP, DeviceNet)
- Lexium Linear Motion single-axis and multi-axis systems adapted to individual requirements in terms of length and stroke, precise to the millimetre

Excellent price/performance ratio

- Economical solution with Modicon M238 logic controller, Lexium 32 Advanced servo drive and Lexium SD3 stepper motor drive

Controllers for Motion Applications

“Flexible Machine Control” brings you maximum flexibility and unprecedented levels of optimisation to put you in full control. The controllers handle the standard logic of the machine and control motion.

The Schneider Electric “Flexible Machine Control” approach provides you with a complete range of controllers from HMI controllers and logic controllers to motion controllers, all with embedded motion functions.

The complete controller range excels with

- A single software environment: Simplify machine programming and commissioning with SoMachine
- Logic and motion programming in a single, fully IEC 1131-compliant environment dramatically reduces programming time and complexity
- All controllers provide a full set of PLCopen function blocks for the entire motion range

Motion controllers for high-performance machines

- Powerful and cost-effective solution for synchronisation of multiple axes
- Extended motion functions such as Virtual Axis, CAM Profiles, Electronic Gear, interpolation, fast response inputs and outputs
- Advanced application function blocks such as Flying Shear, Rotary Knife, Grouping/Ungrouping and Clamping



SoMachine

One for all: a powerful software solution

Motion Controllers

Synchronise up to 8 axes on CANmotion

Powerful motion functions

2½ D Interpolation
Virtual Axis
CAM Profiles ...



HMI controllers Magelis XBTGT/GK

All-in-one device, CANopen

Embedded motion functions for independent axes



Logic controllers Modicon M238 or M258

Flexible and adaptable, PTO or CANopen
Embedded motion functions for independent axes



Motion controllers Modicon LMC058

High performance, CANopen and CANmotion
Advanced motion functions for synchronised axes

Lexium Servo Drives & Motors

Lexium 32 is the perfect drive system for applications involving high-precision, dynamic positioning.

The Lexium 32 servo range consists of three high-performance book-size servo drive models – Lexium 32 Compact, Lexium 32 Advanced and Lexium 32 Modular – and two motor families – the versatile medium-inertia Lexium BMH and the dynamic low-inertia Lexium BSH.

Simplicity throughout the entire lifecycle of your machine

- Fast engineering with powerful integration and design software (motor sizing, CAD and cabinet drawings, support for PLCopen libraries, commissioning software SoMove) reduce time-to-market
- Simplified installation with easy access to removable, colour-coded connectors, memory cards and multi-loader
- Memory cards and standardised FDR function for fast device replacement
- “Safe Torque Off” safety function on board

Openness and modularity

- Intelligent, modular product concept responds to all requirements
- Large selection of fieldbus modules for fast integration into your architecture
- 3 encoder modules for machine encoder/second motor encoder
- Safety module for additional safety functions

Power and performance

- Easy, optimised auto-tuning for different levels of expertise
- Superior motor control
- Intelligent vibration and jerk suppression for long machine life

Top-notch, flange-compatible motor range

- Lexium BMH for applications requiring robust load adaptation and plug-and-play motion tuning with maximum ease
- Lexium BSH for highly dynamic applications

1.6 kHz
speed bandwidth

4 x
continuous current = peak current

Modularity
3 encoder modules = 8 technologies
+ 4 fieldbuses available

Compactness
Superior power density and side-by-side mounting for extremely small footprint



Lexium 32 Compact
for communication via +/- 10V or pulse train input



Lexium 32 Advanced
for CANopen or CANmotion architectures



Lexium 32 Modular
is open for the world of motion with numerous modules



Lexium BMH
is extremely versatile



Lexium BSH
is highly dynamic

Lexium Integrated Drives

Lexium ILx allow for extremely space-saving decentralised motion solutions.

The Lexium ILx Integrated Drives comprise motor, positioning controller, power electronics, fieldbus and “Safe Torque Off” safety function in an extremely compact single device. Lexium ILx Integrated Drives are available with all important motor technologies (servo, brushless DC, stepper).

Compact and cost-effective

- An unprecedented level of integration for new dimensions in machine planning, design and installation
- Reduced cabinet size, less air conditioning in cabinet, less wiring and smaller machine footprint all result in reduced complexity and cost
- The full power and performance of a complete drive with a motor with dimensions as small as 36 x 48 x 52 mm (W x L x H, Lexium ILP/ILT)

Flexible and modular machine concepts

- Three motor technologies - servo, brushless DC, stepper - allow you to combine the individual benefits of each technology: dynamics, flexibility, precision
- 8 fieldbuses for seamless integration into industrial automation environments (RS 485, Profibus DP, CANopen, DeviceNet, Ethernet Powerlink, EtherCAT, Modbus TCP, EtherNet/IP)
- Versatile connection via PCB connectors or industrial connectors

Simple

- Easy and reduced wiring
- Integrated EMC filter*
- Fast and simple commissioning with user-friendly commissioning software
- PLCopen application function blocks included*
- “Safe Torque Off” safety on board*
- Stand-alone device with controller inside (Lexium ILP)

* Lexium ILA, Lexium ILE, Lexium ILS

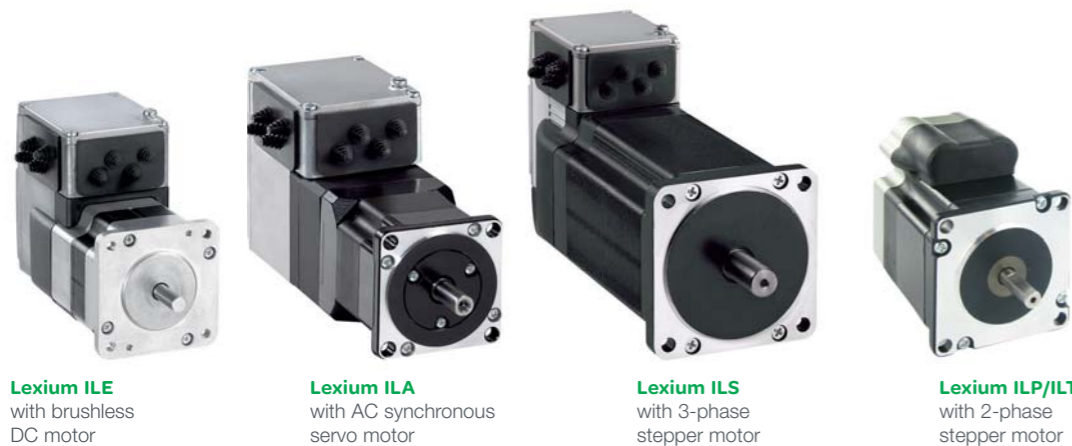

Lexium ILE
with brushless
DC motor

Lexium ILA
with AC synchronous
servo motor

Lexium ILS
with 3-phase
stepper motor

Lexium ILP/ILT
with 2-phase
stepper motor

Lexium Stepper Drives & Motors

Lexium SDx drives and motors are used for short-distance positioning applications requiring maximum accuracy and high torque.

The Lexium SDx stepper motor drive range consists of two high-precision stepper drive lines – the three-phase stepper drives Lexium SD3 and the two-phase stepper drives Lexium SD2. These drive lines are complemented by two perfectly matched stepper motor families – Lexium BRS3 three-phase stepper motors and Lexium BRS2 two-phase stepper motors.

True simplicity

- No encoder systems required
- Plug & play commissioning without software
- “Safe Torque Off” safety function on board*
- High torque ensures that no gearbox is required in most applications
- Automatic current reduction

High-precision performance

- Superior positioning accuracy
- The Lexium SDx drives and sinusoidal commutation of the motors enable practically resonance-free operation
- High power, 5 motor sizes from 0.07 to 16.5 Nm
- Synchronised motion via CANmotion*

Extreme flexibility and compactness

- Control via Pulse/Direction or fieldbus (CANopen, Modbus, Profibus DP)
- Large choice of power classes, accessories and options
- Compact drives (45 x 37 x 59 mm, W x H x D, Lexium SD2) and high power density motors

*Lexium SD3 28



Lexium SD328
3-phase stepper drive
CANmotion architectures

Lexium BRS3
3-phase
stepper motors

Lexium SD2
2-phase
stepper drive

Lexium BRS2
2-phase
stepper motors

Decentralised motion

Save up to

50%

of space in the
control cabinet.

Reduce cabling
by up to

40%

Cut the installation
time by up to

25%

With more than

350.000

Lexium ILx reliably
operating all over the
globe, we are the world
market leader in the area
of compact drives.



Plug & play commissioning

Connect the stepper
motor to the drive,
set the current and
the step resolution –
ready for use!

Maximum accuracy

With step angles of

0.1°

Lexium Linear Motion

Designed for maximum flexibility, performance and cost-effectiveness, this range offers solutions for all linear movements in the automation industry from single-axis to multi-axis systems.

Lexium Linear Motion is a comprehensive linear motion range comprising Lexium PAS portal axes, Lexium TAS linear tables, Lexium CAS cantilever and telescopic axes and Lexium MAX multi-axis systems.

Solutions for all linear motion tasks

- For axis systems below, above and next to the working area, with any combination of arrangements
- Up to three dimensions with stroke lengths of up to 5,500 mm
- Any combination of axis types

Modular kit system for consistent, easy mounting and maintenance

- Axes with identical adaptation and motor interfaces
- Large selection of versions, e.g. for special ambient conditions (corrosion-resistant)
- Common spare parts
- Optimised parts logistics

Customised and complete solutions

- Single-axis and multi-axis systems adapted to individual requirements in terms of length and stroke, precise to the millimetre
- Available with mounted motors and/or gearboxes
- Complete systems available including controllers, drives and motors

Lexium MAX multi-axis concept

This innovative system allows for virtually infinite combinations of all single-axis types to create your own unique multi-axis system.



Complete mechanical solution

Completely pre-assembled with energy supply chain.

<5 minutes
for motor replacement
due to flexible adaptation

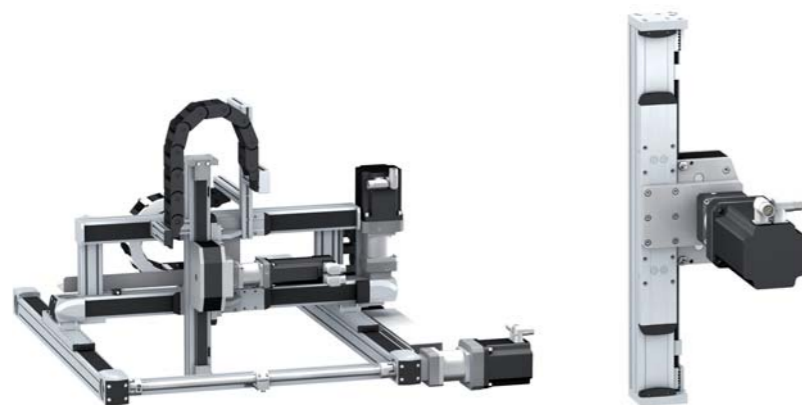

Lexium MAX
Multi-axis systems for 2 or 3 dimensional positioning solutions



Lexium CAS
Standardised cantilever and telescopic axes



Lexium PAS
Portal axes with fixed axis body and moving carriage

Consistency Across the Board

Our motion range is part of our complete Motion & Drives offering. Our efforts to make machine design even more effective for you go far beyond, for example, designing products for identical communication protocols.

Benefit from maximum synergies across different product ranges:

Lexium 32 servo drive



Motion Products

- Controllers
- Servo Drives & Motors
- Stepper Drives & Motors
- Integrated Drives
- Linear Motion



Altivar 32 variable speed drive



Drive Products

- Soft Starters
- Compact Drives
- Standard Drives
- Dedicated Drives
- Engineered Drives

Benefits

- Reduced design and engineering efforts
- Optimised cabinet size and layout
- Optimised parts logistics and inventory

Common tools, software and functionality



Multiloader
to upload and store configurations with power off



Graphic display terminal
to read and adjust parameters in many languages



Bluetooth
for wireless commissioning and maintenance



SoMove and SoMove Mobile, SoMachine
with identical functionality for both drives, where applicable



Common functionality

- Identical HMI
- Identical safety design and functionality (STO, SLS, SS1)

Identical mounting and wiring concepts

- Book size, same heights for side-by-side mounting
- Removable motor connector
- Daisy chaining



Common software support

- PLCopen libraries
- Integration files (EPLAN and CAD)



Common accessories

- Fieldbus modules
- EMC filters
- Braking resistors
- Mains reactors
- Cables



Quick Reference Guide

Product Ranges

Controllers

Lexium Servo Drives

Lexium Integrated Drives

Lexium Stepper Motor Drives

Lexium Linear Motion



Description

The "Flexible Machine Control" approach provides the customer with a complete range of controllers from HMI controllers and logic controllers to motion controllers, all with embedded motion functions.

The Lexium 32 servo range consists of three high-performance book-size servo drive models – Lexium 32 Compact, Lexium 32 Advanced and Lexium 32 Modular – and two motor families – the versatile medium-inertia Lexium BMH and the dynamic low-inertia Lexium BSH.

The Lexium ILx Integrated Drives comprise motor, positioning controller, power electronics, fieldbus and "Safe Torque Off" safety function in an extremely compact single device. Lexium ILx Integrated Drives are available with all important motor technologies (servo, brushless DC, stepper).

The Lexium SDx stepper motor drive range consists of two high-precision stepper drive lines – the three-phase stepper drives Lexium SD3 and the two-phase stepper drives Lexium SD2. These drive lines are complemented by two perfectly matched stepper motor families – Lexium BRS3 three-phase stepper motors and Lexium BRS2 two-phase stepper motors.

Lexium Linear Motion is a comprehensive linear motion range comprising Lexium PAS portal axes, Lexium TAS linear tables, Lexium CAS cantilever and telescopic axes and Lexium MAX multi-axis systems.

Application

"Flexible Machine Control" brings maximum flexibility and unprecedented levels of optimisation to put the customer in full control. The controllers handle the standard logic of the machine and control motion.

Lexium 32 is the perfect drive system for all applications involving high-precision, dynamic positioning.

Lexium Integrated Drives allow for extremely space-saving decentralised motion solutions.

Lexium SDx stepper drives and motors are used for short-distance positioning applications requiring maximum accuracy and high torque.

The Lexium Linear Motion products are designed for maximum flexibility, performance and cost-effectiveness. This range offers products for all linear movements in the automation industry from single-axis to multi-axis systems.

Technical information

All controllers:
Embedded motion functions for independent axes (PLCopen and manufacturer-specific functions blocks)
6 programming languages (IEC 1131-3)
Large choice of digital, analogue and expert IO modules

Communication interfaces
(depending on the controller type): USB, Ethernet, Serial, Profibus DP, CANopen, PTO

LMC058 motion controller:
4 synchronised axes in 2 ms with CANmotion (maximum 8 axes)
Extended motion functions (Virtual Axis, CAM profiles, Electronic Gear, interpolation)
Encoder master input
Fast response inputs/outputs embedded (high speed counters, position capture, reflex outputs, etc.)
64 Mbytes of RAM

Power range: 0.15 to 7 kW
Voltage range: 115 to 240 VAC, 400 to 480 VAC
Speed: up to 8000 rpm
Torque: up to 84 Nm

Communication interfaces: CANopen, CANmotion, Profibus DP, DeviceNet, EtherNet/IP

Safety function (STO) on board
Enhanced Safety Module (SS1, SS2, SLS, SOS)
Encoder module for digital and analog encoders and resolvers

Power range: 100 to 370 W
Voltage range: 24 to 48 VDC, 115 to 240 VAC
Speed: up to 9000 rpm
Torque: up to 12 Nm

Communication interfaces: RS485, CANopen, Profibus DP, DeviceNet, EtherNet/IP, EtherCAT, Ethernet POWERLINK, Modbus TCP, Pulse/Direction

Safety function (STO) on board (Lexium ILA, Lexium ILE, Lexium ILS)
Stand-alone device with controller inside (Lexium ILP)

Power range: up to 750 W
Voltage range: 24 to 48VDC, 115 to 240 VAC
Speed: up to 1000 rpm
Torque: up to 16.5 Nm

Communication interfaces: CANopen, CANmotion, Profibus DP or Pulse/Direction

Safety function (STO) on board (Lexium SD3 28)

Single axes:
Stroke up to 5.5 m
Load up to 150 kg
Speed up to 8 m/s

Multi axes:
Stroke up to 5.5 m
Load up to 300 kg
Speed up to 8 m/s

Available as individual components or completely pre-assembled, customised systems with drives and motors

Machines

Packaging machines
Material handling machines
Material working machines
On-the-fly working machines
Assembling machines

Packaging machines
Material handling machines
Material working machines
Assembling machines

Format adjustment
Printing machines
Material handling machines

Printing machines
Labelling machines
Screen printing machines

Material handling machines
Material working machines
On-the-fly working machines
Assembling machines